

equilibrium constants and the ketonization rates of the corresponding enols as a function of pH. Although these ketones are not directly comparable to **1**, it is apparent that the introduction of a double bond β,γ to the carbonyl group has a large ($>10^5$ -fold) effect on the ionization of the α -hydrogen. The relatively acidic nature of this hydrogen may prove to be important in the elucidation of the mechanism of steroid isomerase.

Acknowledgment. This work was supported by Grant No. GM-33059 from the National Institutes of Health. We thank Dr. Dale L. Whalen for helpful discussions.

Generation of Mono- and Dianions of 1,4-Diphenyl-2-tetrazene by Nonoxidative N-N Bond Formation. A Novel Route to a 2-Tetrazene, a Silacyclotetrazene, and the Tetrazenide Complex (1,4-Diphenyltetrazenido)bis(triethylphosphine)-palladium

Soon W. Lee,^{1a} Glenn A. Miller,^{1a} Charles F. Campana,^{1b} Mary L. Maciejewski,^{1a} and William C. Troglor*^{1a}

Department of Chemistry, D-006
The University of California at San Diego
La Jolla, California 92093
Nicolet Instrument Corporation
Madison, Wisconsin 53711-0370

Received May 4, 1987

Most methods for making N-N bonds use oxidizing conditions.² For example, 2-tetrazenes are synthesized by oxidation of unsymmetrically disubstituted hydrazines.² Carbanion reagents have proved useful for forming bonds between carbon and many elements. For example, Trost and Pearson³ prepared triazenes from the reaction between phenylthiomethylazides and aryl Grignard reagents. Analogous reactions between alkyl amide anions and toluenesulfonyl azide were earlier used⁴ to transfer the alkyl group of an amide to the azide. The intermediate in this reaction was postulated to be a tetrazenide anion. The only known tetrazenide dianion $\text{Li}_2[(\text{Me}_3\text{Si})\text{NN}=\text{NN}(\text{Me}_3\text{Si})]$ is not easily synthesized.^{5,6} In an attempt to prepare symmetrically disubstituted dianions of 2-tetrazenes by the removal of benzoyl groups from 1,4-dibenzoyl-1,4-diphenyl-2-tetrazene,⁷ $\text{Ph}(\text{PhCO})\text{NN}=\text{NN}(\text{COPh})\text{Ph}$, we observed that addition of alkyllithium or Grignard reagents caused fragmentation to phenyl azide (PhN_3) and sodium benzanilide $\text{Na}[\text{Ph}(\text{PhCO})\text{N}]$.⁷ Fragmentation of an incipient tetrazenide monoanion may occur because the oxygen of the carbonyl group better stabilizes negative charge than the π -system of the tetrazene moiety. This raised the question whether the reverse process, addition of a nonstabilized amide ion to an organic

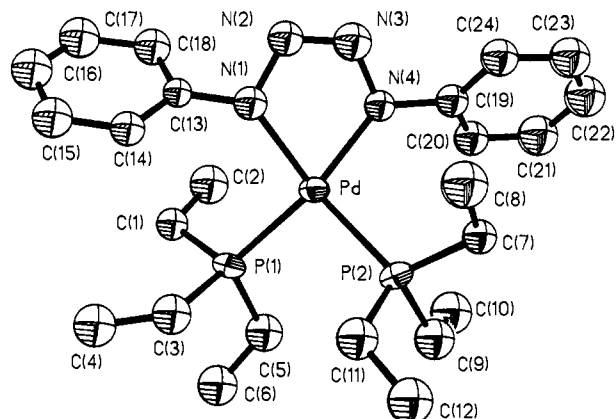
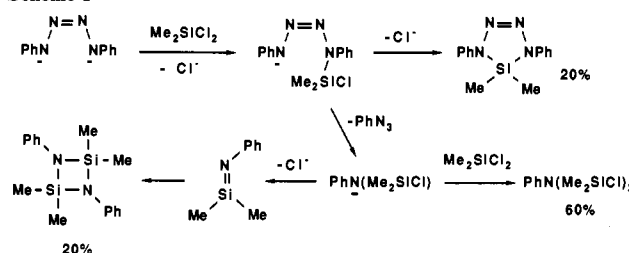
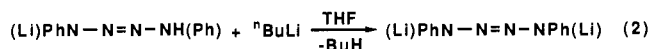

Figure 1. ORTEP drawing of compound III showing the atom labeling scheme and 50% probability thermal ellipsoids.

Scheme I



azide, eq 1, might provide a simple route to tetrazenide mono- and dianions, eq 1 and 2.



A solution of LiNHPh was prepared by adding 10.3 mL of 1.6 M *n*-BuLi (16.5 mmol) in hexane to 1.5 mL (16.5 mmol) of aniline in 25 mL of THF. To this solution was added 7.8 mL (16.5 mmol) of 2.17 M PhN_3 in toluene⁸ and an unstable yellow solid, $[\text{Li}(\text{THF})_x][\text{N}(\text{Ph})\text{NNNH}(\text{Ph})]$, formed. After 1 h 30.9 mL (49.5 mmol) more of the *n*-BuLi solution was added slowly and stirred for 1 h. The yellow slurry of $[\text{Li}(\text{THF})_x]_2[\text{PhN}_4\text{Ph}]$, **I**, was filtered, and the precipitate was washed with hexane. The resulting pyrophoric yellow solid (4.70 g) was dried under vacuum and stored under N_2 . Complex **I** exhibits a slight solubility in THF and benzene. Protic solvents cleave **I** to regenerate aniline and phenyl azide.⁹

Complex **I** serves as a convenient source of the $\text{PhN}^--\text{N}=\text{N}-\text{N}^--\text{Ph}$ dianion. Addition of 2 equiv of CH_3I to **I** produces $\text{Ph}(\text{Me})\text{NN}=\text{NN}(\text{Me})\text{Ph}$ in 60% isolated yield.¹⁰ Treatment of 1.0 g of **I** in 20 mL of THF at -80°C with 10 mL (10 mmol) of a 1.0 M solution of dichlorodimethylsilane (in pentane) gave a light yellow solution. The solution was warmed slowly to room temperature, and the volatiles were removed. Extraction of the residue with warm pentane, followed by concentration and cooling to -80°C , gave the crystalline cyclic tetrazene derivative,

(1) (a) University of California at San Diego. (b) Nicolet Instrument Corporation.

(2) Smith, P. A. S. *Derivatives of Hydrazine and Other Hydronitrogens Having N-N Bonds*; Benjamin/Cummings: London, 1983.

(3) Trost, B. M.; Pearson, W. H. *J. Am. Chem. Soc.* **1981**, *103*, 2483.

(4) Anselme, J.-P.; Fischer, W. *Tetrahedron* **1969**, *25*, 855.

(5) Wiberg, N.; Bayer, H.; Vasisht, S. K. *Chem. Ber.* **1981**, *114*, 2658.

(6) Wiberg, N.; Vasisht, S. K.; Bayer, H.; Meyers, R. *Chem. Ber.* **1979**, *112*, 2718.

(7) The 1,4-dibenzoyl-1,4-diphenyl-2-tetrazene was prepared in 35% yield by oxidation of *N,N*-benzoylphenylhydrazide with lead tetraacetate in CH_2Cl_2 -pyridine: IR (KBr) 1645 cm^{-1} (vs); $^1\text{H NMR}$ (CDCl_3) δ 7.28 (m, Ph), 7.00 (m, Ph) 6.88 (m, Ph). Anal. Calcd for $\text{C}_{26}\text{H}_{20}\text{N}_4\text{O}_2$: C, 74.27; H, 4.76; N, 13.32. Found: C, 74.08; H, 4.94; N, 13.08. For the reaction with methylolithium in diethyl ether (aqueous quench) the fragmentation product PhN_3 was identified by its IR spectrum (2125 cm^{-1} (s) and 2095 cm^{-1} (s)). The 2-phenyl-2-propanol was identified by comparison of its $^1\text{H NMR}$ spectrum and GLC retention time with those of an authentic sample purchased from Aldrich Chemicals.

(8) PhN_3 was prepared as in the following: Lindsay, R. O.; Allen, C. F. H. *Organic Synthesis*; Wiley: New York, 1955; Collect. Vol. III, p 710. The concentration of PhN_3 in toluene was determined by a modified iodometry procedure: Leffler, J. E.; Tsuno, Y. *J. Org. Chem.* **1963**, *28*, 190. Carpenter, W. R. *Anal. Chem.* **1964**, *36*, 2352. Caution: Phenyl azide is explosive; however, it can be stored and used as a nonexplosive toluene solution.

(9) Fragmentation of tetrasubstituted 2-tetrazenes has also been observed by the following: Koga, G.; Anselme, J.-P. *J. Am. Chem. Soc.* **1969**, *91*, 4323. Wadsworth, W. J. *Org. Chem.* **1969**, *34*, 2994.

(10) Elemental analyses and the melting point agree with those of ref 11: $^1\text{H NMR}$ (C_6D_6) δ 7.3 m (10), 3.3 s (6); IR (Fluorolube) 3060, 3040, 2930, 2900, 2850, 1595, 1575, 1450, 1430, 1345; mp $135\text{--}137^\circ\text{C}$ dec.

(11) Fischer, E. *Ann.* **1878**, *140*, 67.

$\text{Me}_2\text{Si-N(Ph)-N=N-N(Ph)}$ (II), in 20% isolated yield.¹² Other products include $\text{PhN(SiMe}_2\text{Cl)}_2$ (ca. 60% by NMR, 24% isolated)¹³ and $(\text{PhNSiMe}_2)_2$ (ca. 20% by NMR)¹⁴ consistent with fragmentation of the monosilated dianion (Scheme I). The presence of PhN_3 (>70%) in the reaction mixture was confirmed by IR spectroscopy. Similarly, treatment of I with excess Me_3SiCl yields only $\text{PhN(SiMe}_3)_2$ in 65% isolated yield.¹⁵ Such fragmentations of trisubstituted tetrazenes have precedent,¹⁶ paralleling the protonolysis reaction of I to give phenyl azide and aniline.

Since electron-rich transition metals should not promote this decomposition route, we reacted I with *cis*- $\text{PdCl}_2(\text{PET}_3)_2$ in an effort to prepare $\text{M}(\text{Ph}_2\text{N}_4)\text{L}_2$.¹⁷ Addition of 0.2 g of I in 15 mL of benzene to a stirred suspension of 0.3 g (0.73 mmol) of *cis*- $\text{PdCl}_2(\text{PET}_3)_2$ ¹⁸ in 15 mL of benzene gave a dark green solution after 5 h. The solution was filtered, concentrated under vacuum, and layered with pentane to yield (40%) green crystals of $(\text{PET}_3)_2\text{Pd-N(Ph)-N=N-N(Ph)}$,¹⁹ III. The molecular struc-

ture²⁰ of III (Figure 1) confirmed trapping of the $\text{PhN}_4\text{Ph}^{2-}$ moiety. The coordination sphere of palladium can be described as a square plane distorted toward a tetrahedral structure (Figure 1) with a 36.6° angle between the planes defined by the metallacycle and PtP_2 fragment. The metallacycle is nearly planar with the average displacement of an atom from the least-squares plane being 0.045 \AA . The dihedral angle of the two phenyl rings with respect to the metallacycle are 51.7° and 46.3° . Of particular interest are the bonds within the metallacycle. The $\text{N}(2)\text{-N}(3)$ bond distance of $1.26(2) \text{ \AA}$ is shorter than the equivalent $\text{N}(1)\text{-N}(2)$ ($1.39(1) \text{ \AA}$) and $\text{N}(3)\text{-N}(4)$ ($1.37(1) \text{ \AA}$) distances. These parameters correspond to one double and two single nitrogen-nitrogen bonds.²¹ The $\text{Pd-N}(1)$ ($2.06(1) \text{ \AA}$) and $\text{Pd-N}(4)$ ($2.04(1) \text{ \AA}$) distances lie within the $1.95\text{-}2.15 \text{ \AA}$ range²² expected for a metal-nitrogen single bond.

Until now most tetraazadiene-metal complexes have been synthesized by the reaction between 2 equiv of an organic azide and a metal complex in a low oxidation state,¹⁷ since the tetrazenide anions were unavailable. Thus the procedures above outline a new method for N-N bond formation and for the synthesis of 2-tetrazenes, 2-tetrazenides, and main-group or transition-metal tetraazadiene (or tetrazenido) complexes.

Acknowledgment. This research is based on work sponsored by the Air Force Office of Scientific Research, Air Force Systems Command, USAF, under Grant AFOSR-86-0027, and W.C.T. thanks the Alfred P. Sloan Foundation for a research fellowship. We thank the DoD Instrumentation Program (Grant DAAL03-87-G-0071) for funds to purchase an X-ray diffractometer.

Supplementary Material Available: Tables of the positional and thermal parameters (6 pages); listing of observed and calculated structure factors (4 pages). Ordering information is given on any current masthead page.

(12) ¹H NMR (C_6D_6) δ 7.3–6.7 (m, 10 H, Ph), 0.14 (quint, 6 H, Me); mp 111–113 °C; MS, exact mass 268.1148 (calcd 268.1144, $\Delta = +1.5$ ppm); EI 268 (20), 240 (20), 225 (27), 149 (100). Anal. Calcd for $\text{C}_{14}\text{H}_{16}\text{N}_4\text{Si}$: C, 62.58; H, 6.01; N, 20.95. Found: C, 62.83; H, 5.92; N, 20.65.

(13) ¹H NMR (CCl_4) δ 7.3–7.0 (m, 5 H, Ph), 0.42 (s, 12 H, Me); bp 55–65 °C/0.001 mmHg; MS, exact mass 277.0279 (calcd for ³⁵Cl 277.0277, $\Delta = +0.7$ ppm); EI 277 (43), 262 (64), 242 (12), 226 (23), 149 (100) (all but the last ion fragment have expected isotope pattern(s) for one or two chlorines). Anal. Calcd for $\text{C}_{10}\text{H}_{17}\text{Cl}_2\text{NSi}_2$: C, 43.16; H, 6.17. Found: C, 42.96; H, 6.58. The material is extremely reactive toward moisture and glassware.

(14) (a) This material was purified by sublimation (180 °C, 0.001 mmHg); mp 250–252 (lit. 252.5^{b,c}); MS, exact mass 298.1355 (calcd 298.1322, $\Delta = +1.2$ ppm); EI 298 (81), 283 (100), 149 (18). (b) Fink, W. *Helv. Chim. Acta* **1964**, *47*, 498. (c) Fink, W. *Angew. Chem., Int. Ed. Engl.* **1966**, *5*, 760.

(15) The NMR spectrum is identical with that of $\text{PhN(SiMe}_3)_2$ prepared by the following: (a) Abel, E. W.; Willey, G. R. *J. Chem. Soc.* **1964**, 1528. (b) Wannagat, V. U.; Krüger, C.; Niederprüm, H. *Z. Anorg. Chem.* **1962**, *314*, 80.

(16) Wiberg, N. *Adv. Organomet. Chem.* **1985**, *24*, 179.

(17) (a) Overbosch, P.; Van Koten, G.; Grove, D. M.; Spek, A. L.; Duisenberg, A. J. M. *Inorg. Chem.* **1982**, *21*, 3253. (b) Cenini, S.; LaMonica, G. *Inorg. Chim. Acta* **1976**, *18*, 279. (c) Maroney, M.; Trogler, W. C. *J. Am. Chem. Soc.* **1984**, *106*, 4144. (d) LaMonica, G.; Sondrinic, P.; Zingales, F.; Cenini, S. *J. Organomet. Chem.* **1973**, *50*, 287. (e) Gross, M. E.; Trogler, W. C.; Ibers, J. A. *J. Am. Chem. Soc.* **1981**, *103*, 192. (f) Cenini, S.; Fantucci, P.; Pizotti, M.; LaMonica, G. *Inorg. Chim. Acta* **1975**, *13*, 243. (g) Gross, M. E.; Trogler, W. C. *J. Organomet. Chem.* **1981**, *209*, 407. (h) Trogler, W. C.; Johnson, C. E.; Ellis, D. E. *Inorg. Chem.* **1981**, *20*, 980. (i) Overbosch, P.; Van Koten, G.; Overbeek, O. *J. Am. Chem. Soc.* **1980**, *102*, 2091. (j) Dekker, M.; Knox, G. R. *Chem. Commun.* **1967**, 1243. (k) Ashley-Smith, J.; Green, M.; Stone, F. G. A. *J. Chem. Soc., Dalton Trans.* **1972**, 1805. (l) Doedens, R. *J. Chem. Commun.* **1967**, 1243.

(18) Doyle, J. R.; Slade, P. E.; Jonassen, H. B. *Inorg. Synth.* **1960**, *6*, 218.

(19) ³¹P{H} NMR (C_6D_6) δ 60.3 (s); mp 122–124 °C with liberation of gas. Anal. Calcd for $\text{C}_{24}\text{H}_{40}\text{N}_4\text{P}_2\text{Pd}$: C, 52.1; H, 7.29; N, 10.1. Found: C, 51.7; H, 7.03; N, 9.63.

(20) The crystal data is as follows: $\text{C}_{24}\text{H}_{40}\text{N}_4\text{P}_2\text{Pd}$, monoclinic, $P2_1/c$, $a = 12.904(3) \text{ \AA}$, $b = 13.405(4) \text{ \AA}$, $c = 16.670(4) \text{ \AA}$, $\beta = 112.01(3)^\circ$; $V = 2673(2) \text{ \AA}^3$, $D_c = 1.37 \text{ g cm}^{-3}$, $Z = 4$, $F(000) = 1152$, $(\text{Mo K}\alpha) = 0.71073 \text{ \AA}$ (graphite monochromator), $\mu = 7.9 \text{ cm}^{-1}$. Method: Nicolet R3 diffractometer; all non-hydrogen atoms were located by SHELXTL PLUS computer programs (Nicolet Instrument Corp., Madison, WI); difference Fourier and refined by full-matrix least squares. Refinement of 1111 unique observed reflections ($I > 3\sigma I$) out of 2136 measured ($3^\circ < 2\theta < 45^\circ$), gives R and R_w values of 0.050 and 0.042, respectively. Hydrogen atoms were not included, and the carbon and nitrogen atoms were refined with isotropic temperature factors. The thermal motion of the other atoms was dealt with anisotropically.

(21) Compare with the following: (a) *trans*-tetrazene, $\text{H}_2\text{N-N=N-NH}_2$: $\text{N-N} = 1.43(1) \text{ \AA}$; $\text{N=N} = 1.21(2) \text{ \AA}$. Veith, M.; Schlemmer, G. *Z. Anorg. Chem.* **1982**, *494*, 7. (b) Tetrakis(trimethylsilyl)tetrazene: $\text{N-N} = 1.394(5) \text{ \AA}$; $\text{N=N} = 1.268(7) \text{ \AA}$. Veith, M. *Acta Crystallogr., Sect. B: Struct. Crystallogr. Cryst. Chem.* **1975**, *31*, 678.

(22) Davis, B. R.; Payne, N. C.; Ibers, J. A. *Inorg. Chem.* **1969**, *8*, 2719.